

955 Benton Ave., Winslow, ME 04901 • Phone: 1-877-564-6697 • Fax: 1-800-738-6314
Email: service@johnnyseeds.com • Web Site: Johnnyseeds.com

Summer-bearing and Everbearing Raspberries (*Rubus spp.*)

Check your transplants immediately upon receipt. Remove the packing materials and transplant as soon as possible. If you are unable to transplant them right away, we recommend the following:

- **Bare-root dormant plants that have not yet leafed out are frost tolerant. Check the medium protecting the plant roots; it should be damp; moisten if dry. Place plants back inside the liner and box and store in a refrigerator or cool location for up to 1 week at 32–40°F (0–4°C). Keep the roots damp.**
- **Greenhouse-grown plants with fresh, green leaves ship only after the danger of frost has passed. Check the medium protecting the plant roots; it should be damp; moisten if dry. The open box and liner can be used to hold the plants in a well-lit, ventilated area until planting out. Do not store in the refrigerator; plants with leaves are susceptible to frost and chilling damage.**

LIFE CYCLE / HARDINESS

Perennial. Hardiness varies by variety; please check our catalog or website descriptions for more information.

SITE SELECTION

Raspberries thrive in a sunny, open location with well-drained soil. A slightly sloped area that encourages good air and water movement is desirable. Many disease and environmental problems can be minimized by planning ahead and planting in an appropriate site. Soil that remains water-saturated can lead to winter injury or disease problems. If your site is poorly drained, consider using raised beds. A fertile soil with a pH of 5.5–6.5 is optimal. Do not plant raspberries in areas that have been previously planted with raspberries, strawberries, or crops in the Solanaceae family, as diseases can be passed on to the new planting.

PLANTING

Adequate spacing is important for best yields. Beds should be 2' wide, with paths between the beds that are a minimum of 8' wide. This spacing allows the plants to fill in the bed as well as room for mowing equipment in the paths if needed.

The paths can be planted with grass or other cover crops, such as clover, or mulched with bark or straw. Space plants 1½–2' apart in the row.

Transplanting bare-root plants. Spread the roots out laterally from the stem when planting and cover with ½-1" of soil. Water well after planting.

Transplanting greenhouse-grown plants with leaves. Transplant deeply enough to cover plug soil with ½–1" garden soil. Irrigate well after transplanting and maintain good moisture levels until plants are well-established or for 4–6 weeks after transplanting.

WATERING / IRRIGATION

Proper soil moisture is especially important during the establishment year, and is best achieved with drip irrigation. The plants may be slow to form new growth and the existing canes may not develop leaves if proper soil moisture is not maintained. Simply check for root development to ensure that the plants are taking hold.

FERTILITY

Beginning in the spring of their second year, side-dress plants with a balanced fertilizer at a rate of 1 pound per 100 ft² area. Repeat in midsummer if needed.

WEED CONTROL

Weed control for raspberries is important for best yields and plant health. We recommend that you plant your raspberries in an area that has already been tilled and weeded — preferably an area previously planted with a cover crop for suppression of perennial weeds. After planting, cultivate weekly to control weeds while the raspberries are becoming established. Mulching with straw or bark is an effective option for controlling weeds and retaining soil moisture.

PRUNING

Proper pruning is an important contributing factor to a successful raspberry harvest. See below for information specific to summer-bearing and everbearing raspberry types.

Summer-bearing types

Also known as floricane raspberries, summer-bearing raspberries produce fruit only on second-year canes. During their first growing season after planting, allow the plants to become established, which helps to ensure that the first-year primocanes remain intact through the winter. During their second growing season after planting, any canes that formed during the first year will bear fruit and can be pruned at ground level after they fruit and harvest is complete. New canes that form during the second year can be pruned out to leave 6–8 healthy canes per bed-foot, to prevent overcrowding. Continue this pattern in following seasons, removing spent canes (second-year canes that have fruited), as well as diseased or broken canes, and thinning new canes.

Everbearing types

Also known as primocane raspberries, everbearing raspberries bear a late-season crop at the tops of first-year canes and a main-season crop on second-year canes. To produce one large, late-season crop instead, prune all canes to the ground after harvest in the fall or in the early spring. To produce a moderate main-season crop *and* a late-season crop, prune as you would a summer-bearing type.

TRELLISING

A good trellising system can improve yield along with facilitating harvest and maintenance. Raspberries can be grown without trellising, but will need to be topped or cut back to prevent canes from breaking. Since many of the fruit buds occur along the top half of the cane, topping a plant can reduce the productivity of the planting. Described below are two main types of trellis systems recommended for the two types of raspberries.

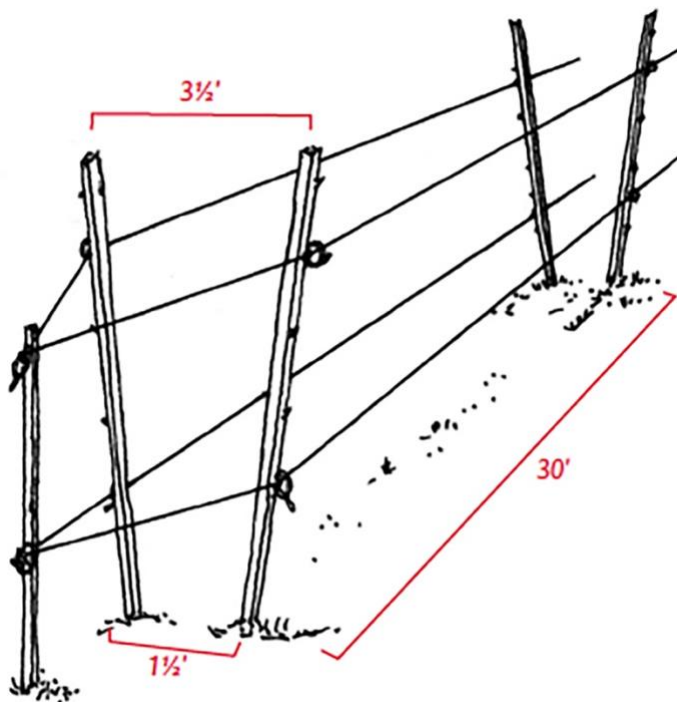

Summer-bearing (Floricane) Types

Competition between fruiting (second-year) and vegetative (first-year) canes can be reduced by using a system that separates the fruiting canes from the primocanes.

V-trellising is the most widely used form of trellis for summer-bearing raspberries. In a V-trellis system, posts are set at a 20–30° angle along both outer margins of the planting bed. The tops of the posts should stand about 6' above ground and diverge about 3 1/2'. Wires are then strung from post to post along the length of the bed. Fruiting canes are tied to the wires running along the exterior arms of the V while primocanes are allowed to grow up within the interior/center of the bed. Harvesting and caring for the floricanes is easier because they are more accessible along the edges of the bed.

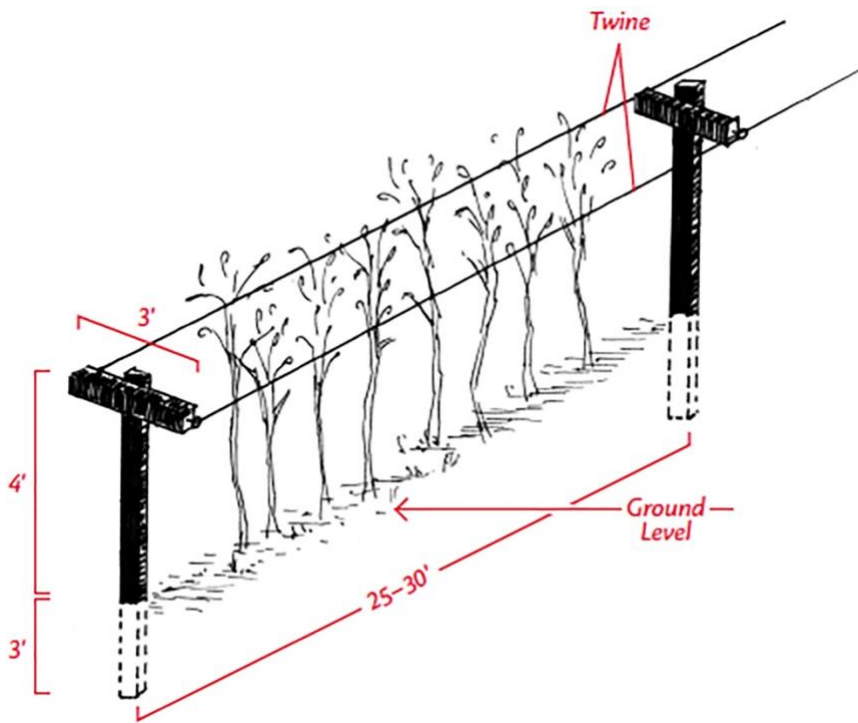

Everbearing (Primocane) Types

Primocane-fruited raspberries have a tendency to lean over and break, due to their top-heavy canes. This can be prevented with T-trellises, the most popular form of trellising for everbearing raspberries. The posts, which can be made of metal or wood, should be about 7' tall, with 3½–4' of the post standing above ground and a 3'-long cross-arm secured across the top of the posts. The posts are set in holes dug into the center of the bed rows, spaced 25–30' apart in the row. Twine is run between the posts and attached to either side of the crossbar at the tops of the posts. The canes are corralled within the structure.

DISEASES AND PESTS

Raspberries are susceptible to a number of pests and diseases, including Japanese beetles, spotted wing drosophila (SWD), and verticillium wilt. To learn more, see our [Raspberry Pests and Diseases Tech Sheet](#). Contact your local Cooperative Extension Service office or consult a raspberry culture guide for more detailed information.

HARVEST

With summer-fruited varieties, begin harvesting the second year. With everbearing varieties, you may be able to harvest a small crop during the first year, with full yields beginning the second year. Raspberries for fresh eating are almost always harvested by hand, as they are delicate and do not ripen uniformly enough to machine harvest. Keep berries cool after harvest, and be careful not to crush them. Raspberries can be stored by freezing whole.

REFERENCES AND FURTHER READING

Trellis drawings: Bushway, L.J., et al. 2008. Raspberry and Blackberry Production Guide for the Northeast, Midwest, and Eastern Canada (NRAES-35). URL: <https://hdl.handle.net/1813/66930> (accessed 01.23.2023).

New York State Integrated Pest Management Publication No. 228. 2021. Organic Production and IPM Guide for Raspberries and Blackberries. URL: <https://ecommons.cornell.edu/bitstream/handle/1813/42889.3/2022-org-rasp-blackberry-NYSIPM.pdf> (accessed 01.23.2023).

TunnelBerries.org/USDA-SCRI. 2019. High Tunnel Production Guide for Raspberries & Blackberries. URL: <http://www.hort.cornell.edu/fruit/pdfs/high-tunnel-brambles.pdf> (accessed 01.23.2023).