



955 Benton Ave., Winslow, ME 04901 • Phone: 1-877-564-6697 • Fax: 1-800-738-6314  
 Email: service@johnnyseeds.com • Web Site: Johnnyseeds.com

The concept of a wheel hoe that simultaneously works both sides of a row has been around for more than 100 years. Unfortunately, as technology advanced and farms expanded their production in the early part of the 20<sup>th</sup> century, this simple yet effective tool was forgotten. We are very pleased to re-introduce this design in an age when small farms are again thriving, and the consumption of fresh local food is being embraced by many.

The primary benefit of this design is reduced labor by only having to make one pass at a single row for cultivating. In addition to reducing repetitions by half, the U-Bar is able to cultivate crops further into their maturity because of its high clearance and the employment of leaf lifters, which gently guide foliage through the chassis. In our trials, we were able to cultivate many crops until they reached a height of 16 inches with little or no crop damage.



*U-Bar Wheel Hoe equipped with Disc Harrow Ganges for hilling corn.*

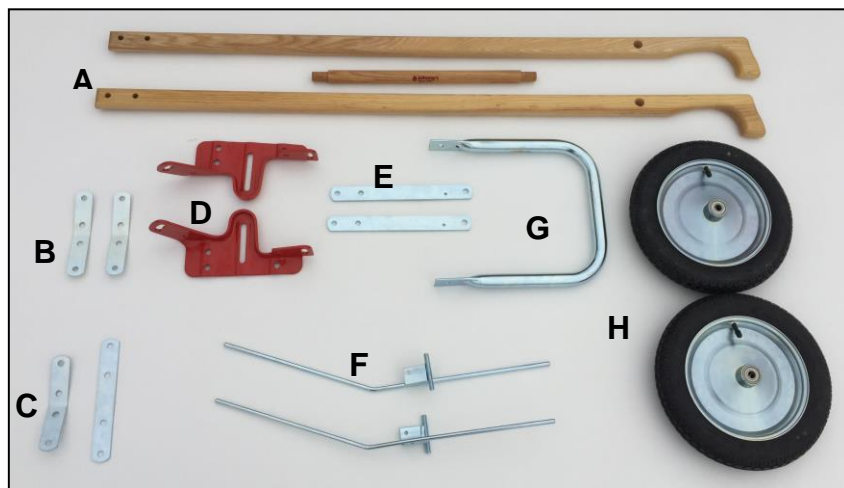

**Parts Included:**

- A. (2) Wooden handles and (1) dowel.
- B. (2) Traditional handle brackets.
- C. (2) Off-set handle brackets.
- D. (1) Split chassis.
- E. (2) Wheel support brackets.
- F. (2) Leaf lifters.
- G. (1) U-Bar.
- H. (2) Wheels with standard U.S. inflation stem; inflate tires to 30 psi.

### Hardware Included:

- A. (12) 17mm hex nuts
- B. (6) M10- 1.5 x 25mm hex bolts
- C. (2) M10- 1.5 x 20mm hex bolts
- D. (4) 10mm flat washers
- E. (4) M10- 1.5 x 45mm carriage bolts
- F. (4) 17mm nylon-insert lock nuts
- G. (2) M12- 1.75 x 110mm axle bolts
- H. (4) 12mm flat washers
- I. (2) 19mm nylon-insert lock nuts
- J. (2) 20mm hex bolts
- K. (2) 10mm nylon-insert lock nuts
- L. Wrench set



## ASSEMBLY

### FRAME

Fasten the U-Bar and the wheel support bracket to the chassis using four 25mm hex bolts (B) and four 17mm hex nuts (A). See right. Wheel support bars should be fastened to the inside of the chassis and the U-Bar should be fastened to the outside, sandwiching the chassis in between the two. See below.

**Note:** Make sure that the smaller holes drilled in the forward part of the wheel support brackets are oriented up. See arrows on right.

Lightly tighten the four hex bolts to secure the wheel support brackets, U-Bar, and the chassis, as adjustment will likely be needed later.

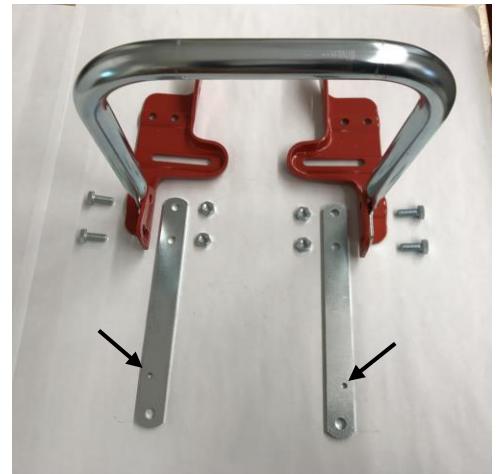

### WHEELS

Install one axle bolt (G) through each wheel, making sure there is a washer on either side of the bearings. See right.



Once the tires have been installed onto the wheel support brackets, you may tighten the 19mm nylon-insert lock nuts (I) to secure the wheels in place. See left.

**Note:** You may need to use a screwdriver to center the inner housing of the tire to insert the axle bolt properly.



### HANDLES

Insert the dowel into each handle making sure the grips are both oriented in the same direction. If the fit is tight, work the dowel and handles together by spinning them back and forth while applying some force. A light sanding may also be needed.



## HANDLE ARRANGEMENT OPTIONS

Once your handles are assembled, you can choose to install the traditional handle brackets or the off-set handle brackets. See below for more information on the benefits of each type of installation.

The brackets for both options are installed using 25mm hex bolts (B) and 10mm washers (D) in the elongated holes toward the back of the chassis, and a 20mm hex bolts (C) without washers in the single holes. See right.

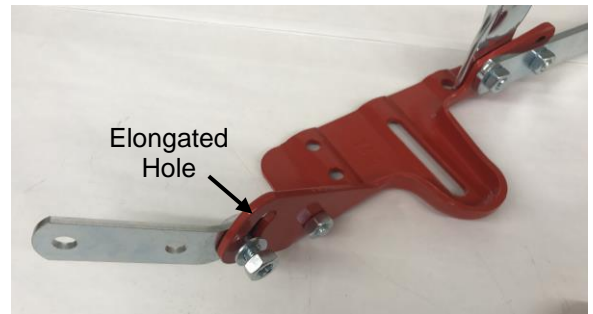

**Note:** Traditional handle installation uses two angled brackets. Off-set handle installation uses one straight and one angled bracket. *Angled handle brackets should be installed so the handle will flare out, away from the chassis. See photos below for correct orientation for both handle arrangements.*

Once you have your desired handle brackets installed on both sides of the chassis, use the four 45mm carriage bolts (E) and remaining 17mm hex nuts (A) to secure the wooden handles to the brackets. Fasten all four nuts onto the bolts before tightening them.

### Option One: Traditional Handle Brackets

With traditional handle brackets, the user walks directly behind the wheel hoe, using a straight forward-and-back pushing motion. This allows for greater precision and the greatest amount of force to be applied. This arrangement may be desirable for hilling row crops or for working in soils that are heavy, rocky, or compacted and is suitable for extended use in most situations. The downside associated with the traditional handle position is that it's necessary to walk in your bed, thus compacting the soil in your beds.



### Option Two: Off-Set Handle Brackets

Off-set handles allow the user to cultivate row crops from the footpath, minimizing soil compaction in your beds. This arrangement is most effective on finely prepared beds that are not compacted because the amount of force the user can apply is reduced. Working from the path may also be required for crops that are too tall to easily walk over such as corn, kale, tomatoes, or broccoli.

These brackets are very similar to the traditional-style brackets except one of them is straight. The setup shown to the right would be used to work the bed on your right as you walk down a row. This is preferable for most right-handed people. Simply reverse the brackets to achieve a left-handed orientation.



## LEAF LIFTERS

Leaf Lifters are designed to guide foliage through the center of the chassis without damage. They can be adjusted taller for transport, or lowered when in use, without the need for tools.



Begin by fastening the four 17mm nylon-insert lock nuts (F) to the threaded rod that has been welded to each leaf lifter. See left. Once the threads have fully engaged the nylon, stop tightening to avoid damage.

Next, fasten the leaf lifters to the frame using the small 20mm hex bolts (J) and 10mm nylon-insert lock nuts (K). These need to be tight enough to hold the leaf lifters in place, while still allowing for adjustment without the need for a wrench.



## ADJUSTMENTS

### HEIGHT OF THE CHASSIS/ DEPTH OF THE CUT

The angle of the wheel brackets can be adjusted to alter the depth of the cutting blades. With most cultivating attachments, the wheels brackets should be adjusted so that the blade is only penetrating  $\frac{3}{4}$ – $1\frac{1}{2}$  inches (2-4cm) into the soil.

**Note:** *The chassis stays relatively parallel to ground despite adjusting the height.*

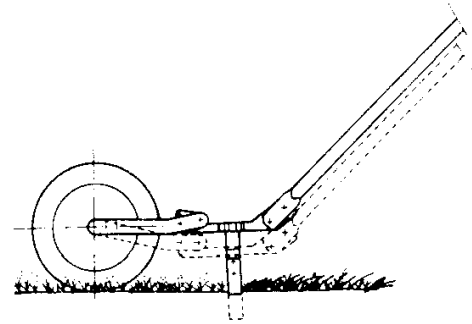

Depth Adjustment

### ANGLE OF THE CUT

The chassis should be almost parallel with the ground for most cultivation. However, harder compacted soils may require a more aggressive cutting angle up to 10 degrees for greater effectiveness.

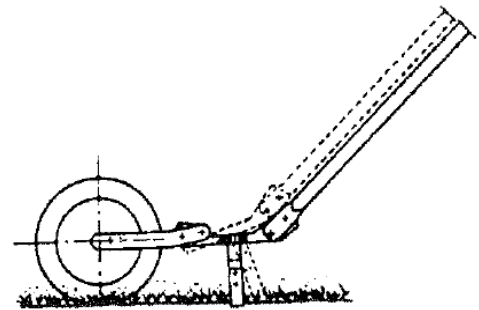

Angle Adjustment

### HANDLE HEIGHT

The handle height can be adjusted by loosening the bolts and pivoting them at their connections to the chassis. The ideal handle height for operation should be slightly above the user's hips. Once the desired height is set, tighten the bolts on the chassis to secure the handles in place.

**Note:** *Experiment with the handle height until you find a comfortable working position for your body.*

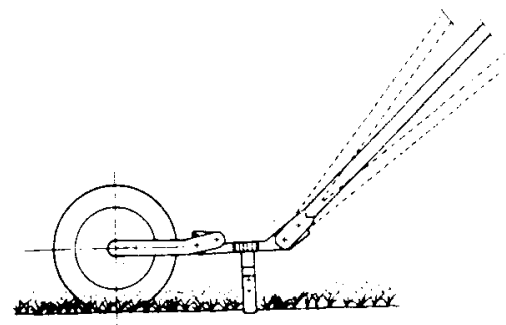

Handle Adjustment

### LEAF LIFTERS

The nylon-insert lock nuts on the threaded rod can be used to adjust the height of the leaf lifters so that they match each other, or as needed. The leaf lifters may also be removed entirely for cultivation of shorter or less mature crops.

## U-BAR ATTACHMENTS (Sold Separately)

### Beet Knife Sweeps

These are a great first accessory tool for the U-Bar because they are so adaptable. There are three ways to use these versatile attachments:

1. When facing inward, they are effective at cultivating underneath crops can be angled inward to cultivate around wider or low-growing crops like lettuce. See right.
2. Adjust the beet knives so that they are almost touching each other to easily cultivate large areas of ground.
3. When blades are set facing outward, the beet knives are especially well adapted to cultivate row crops with a more vertical growth habit, such as onions, leeks, and corn. See right.

The Beet Knife Sweeps are effective when used with both traditional and off-set handle positions.



### Disc Harrow Gangs

These miniature disc harrows have been proven to be very effective for both in-row and inter-row weed management and hilling young seedlings like onions, beans, corn, and carrots. The angle of the gangs is fully adjustable, making them useful for lightly hilling and cultivating a variety of crops.

Disc Harrow Gangs are effective when used with both traditional and off-set handle positions.



### Hilling Plow Blades

These attachments can be configured with the blades facing towards each other for hilling crops such as corn, potatoes, and beans (shown below), or away from each other to create a plow to dig furrows for planting. See photos to the right for proper installation for these two methods.



Hilling Plow Blades are also effective for in-row cultivation by hilling soil onto the base of your crops and smothering small weeds.



Set for Hilling



Set for Plowing

The hilling plow blades can be difficult to manage with the off-set handles so we recommend using these attachments with your U-Bar Double Wheel Hoe set to the traditional handle position.

REV 06/05/2018 JG, Id